

Simply **Sixteen**TM by Handi Quilter[®]

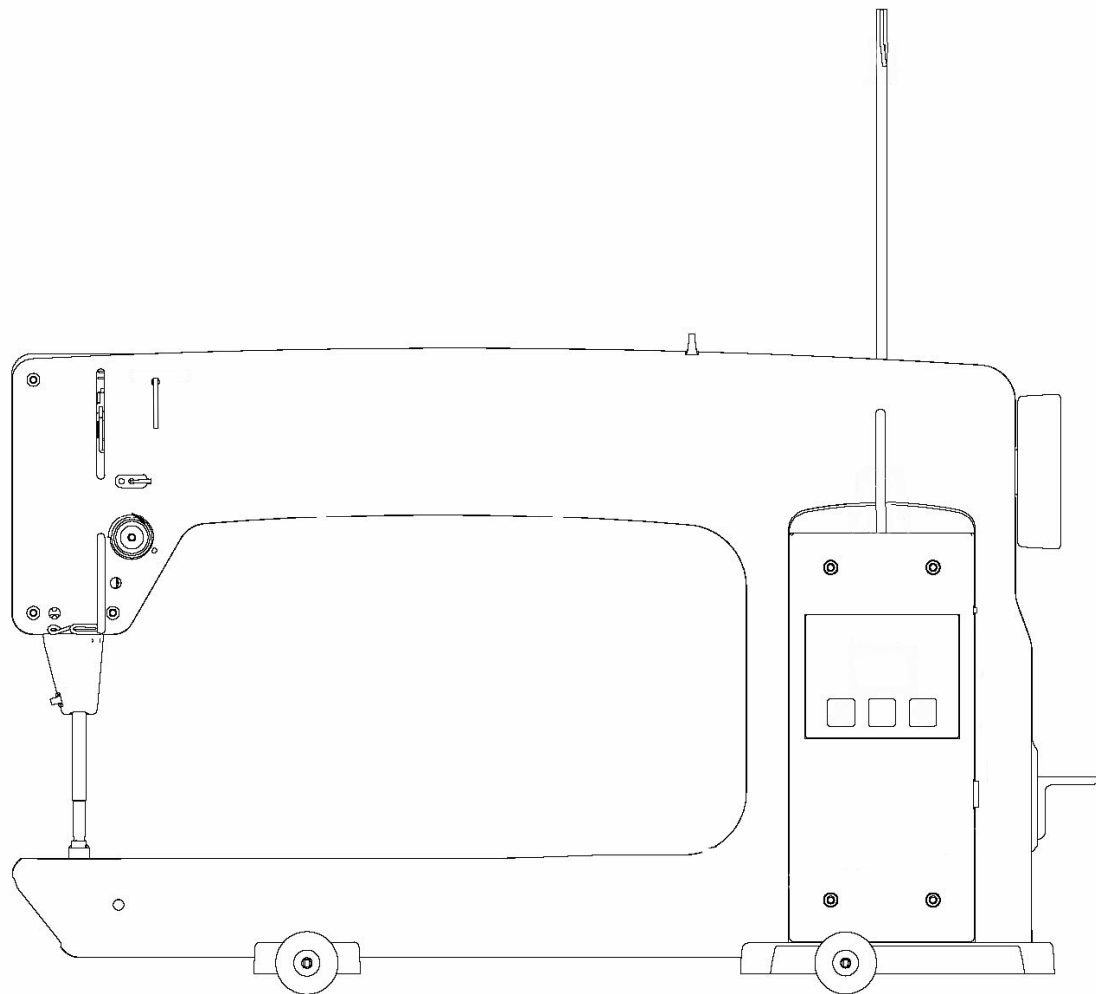

Copyright© 2006 "All Rights Reserved"
No part of this manual may be reproduced in whole or part without
express written consent from Handi Quilter, LLC

Contents

Safety Section and Quick Facts	1
Package Contents and Machine Components	2-3
Installation Procedures	4-6
Laser Style Safety and Use Guidelines.....	7
Threading the Machine	8-9
Bobbin and Thread Tension Adjustments	10
Maintenance	11
Front Handlebar Controls	12-13
POD Controls	14
Thread and Quilting Recommendations.....	15
Troubleshooting.....	16-18

Safety Section

Please note: Do not operate your Simply Sixteen™ quilting machine until you have completely read the information contained in this manual. Please keep all packaging and order information for warranty purposes.

1. Always unplug the Simply Sixteen™ from the electric outlet when performing any maintenance, changing the needle, removing thread locks, or when left unattended.
2. Keep fingers away from all moving parts. Use caution around the needle or sharp external components.
3. Change the needle often. Do not use bent or dull needles.
4. Switch the power off when making any adjustments in the needle or bobbin area, such as threading the needle, installing the bobbin case, or when oiling or cleaning.
5. Never drop or insert foreign objects into any opening.
6. The Simply Sixteen™ should only be used indoors away from moisture.
7. The Simply Sixteen™ should not be stored or used in extreme temperatures.
8. Use the Simply Sixteen™ only for its intended use as described in this manual.
9. Use only attachments recommended by the manufacturer in this manual.
10. To disconnect from the wall outlet, push the switch to the off position, then remove the plug from outlet pulling from the plug, not the cord. Never operate the Simply Sixteen™ if the cord is damaged or not working correctly. If a mechanical or electrical problem is encountered, return the Simply Sixteen™ to the nearest authorized service center or the manufacturer for examination, repair, electrical or mechanical adjustment.
11. It is not recommended that the Simply Sixteen™ Quilting Machine be used with any home machine quilting frame other than those recommended or manufactured by Handi Quilter LLC.

Quick Facts

Description	Specification
Sewing Speed	Approximately 1,500 spm
Minimum Sewing Speed	150 spm
Needle Bar Stroke	35.3 mm
Sewing Foot Stroke/Lift	5 mm
Needle System	135x7 Standard 134 R Long Scarf
Needle Sizes	14/90 – 19/120
Lubricating Oil & Greases	Kluber Lubrication
Dimensions of Sewing Machine Throat	8.25" x 16.00"
Rate Voltage/Power Consumption	120 volts, 60 Hz 100 watts
Power Consumption of LED Lights	20 watts
Hook System	Custom Manufactured, Rotary, Large Bobbin
Bobbin Type	Class M
Motor Type	Brushless DC, Internal Encoding
Automatic Needle Positioning	Up and down, full stitch and half stitch

Disclaimer

Handi Quilter LLC and its Representatives are in no way legally responsible or liable for damage to the Simply Sixteen when used improperly or not in accordance with the guidelines stated in this manual or when used on Home Machine Quilting Frames not recommended by Handi Quilter LLC.

Home Machine Quilting Frame Recommendations

- › Handi Quilter Original Home Machine Quilting Frame
- › HQ II Home Machine Quilting Frame
- › HQ Portable Professional Home Machine Quilting Frame

Package Contents

Please keep your original box and packaging

Contents of Package

1. Bobbins (5 pieces)
2. Needle (135x5) size 16
3. Needle (135x5) size 18
4. Bobbin Case
5. Thread Mast
6. Oiler
7. Power Cord
8. Hex Wrench (2 – for needle clamp & handlebars)
9. Instructional DVD
10. Instruction Manual
11. Simply Sixteen Quilting Machine

Optional Accessories

1. Front Handles
2. Laser Stylus and Clamp
3. Laser Stylus Post

Simply Sixteen™ Components

Front Side Diagram A

1. Thread Mast
2. Thread Guide A
3. Three Hole Thread Guide B
4. Thread Guide C
5. Tension Assembly
6. "Stirrup" Thread Guide D
7. Take Up Lever
8. Thread Guide E
9. Needle Bar Thread Guide
10. Needle
11. Front Casing/Frame
12. Hand Wheel
13. Pod Display
14. Side Laser Stylus Post Hole

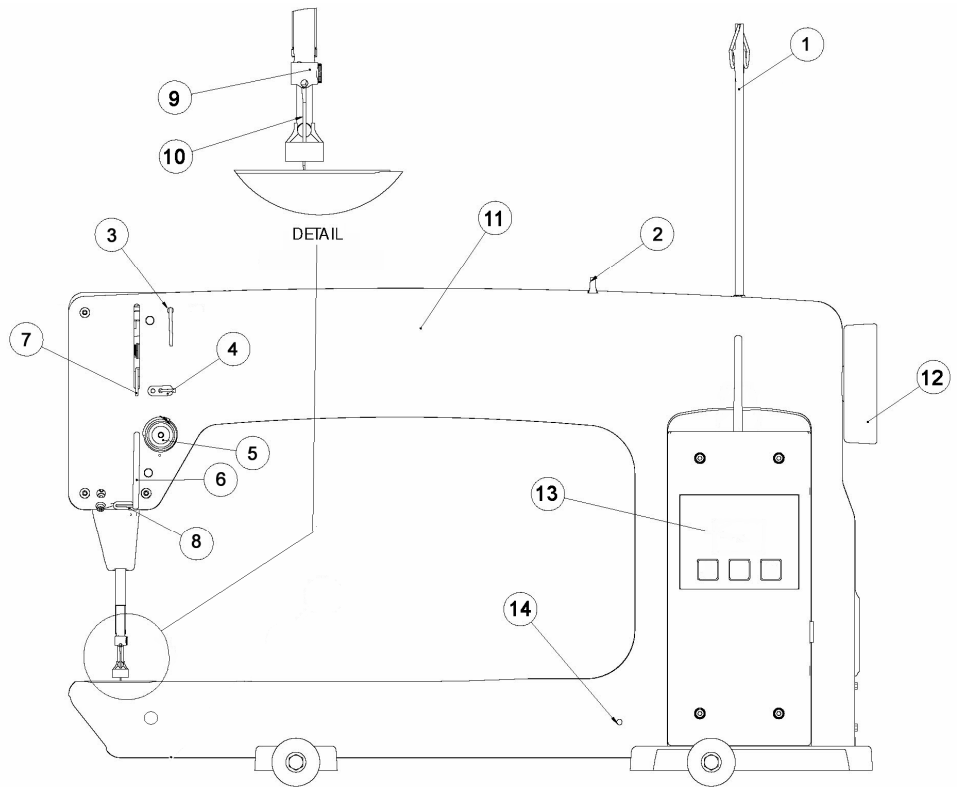

Diagram A

**Back Side
Diagram B**

- 15. Hopping Foot
- 16. Needle Bar
- 17. Presser Bar
- 18. Back Casing/Frame
- 19. Front Handle Connector
- 20. Top Laser Stylus Post Hole
- 21. Front Threaded Handle Holes
- 22. Bobbin Assembly
- 23. Needle Plate
- 24. Front Wheel Base
- 25. Oval Position Guides
- 26. Rear Wheel Base
- 27. Wheels (4)

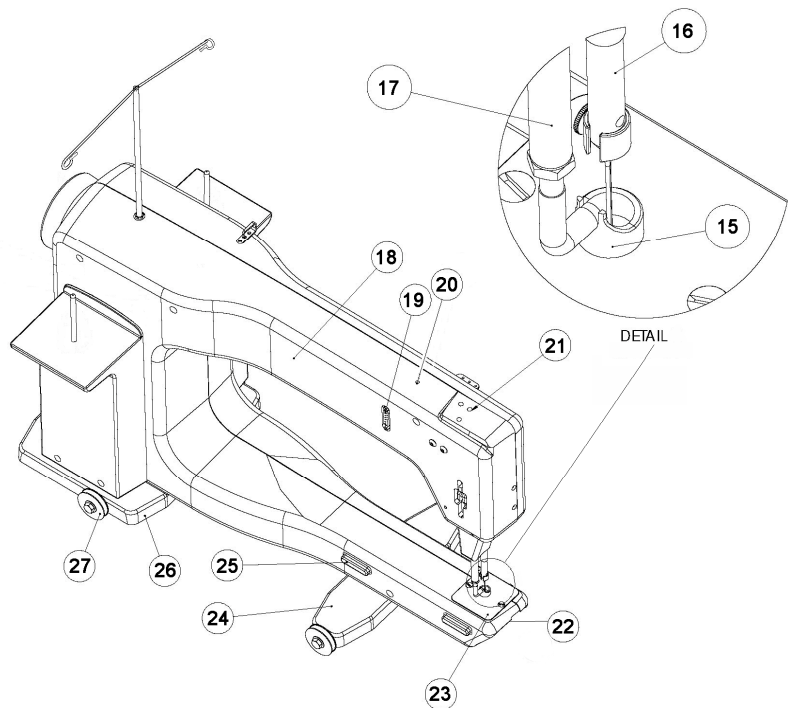

Diagram B

**Rear
Diagram C**

- 28. Spool Pin 1
- 29. Laser Stylus Power Connector
- 30. Front Electronic Control Pod
- 31. Serial Port for Upgrade
- 32. Foot Pedal Connector
- 33. Rear Upgrade Port
- 34. Rear Threaded Handle Holes
- 35. Power Cord Connector
- 36. On/Off Switch
- 37. Back Power Pod
- 38. Spool Pin 2

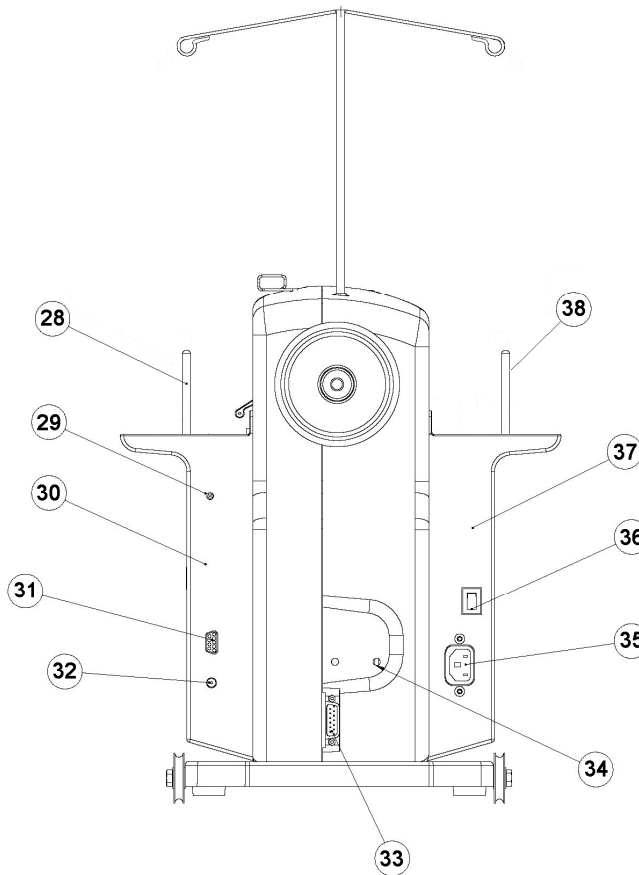

Diagram C

Note: A Handi Quilter “Welcome” DVD is included with your Simply Sixteen™ Machine. Review the DVD and these instructions to better understand how to setup and use the Simply Sixteen™.

Installing Front Handlebar

Caution: Unplug the Simply Sixteen™ from the electric outlet. All power to the machine must be turned off when installing the front handles. Failure to do so can result in damage to the machine.

Important note: Care must be taken to not pinch the ribbon cable under the handle bar when it is tightened to the machine. Locate the three longest bolts and the appropriate Hex wrench. To install the handles, line up the three holes on top of the handles with the three pre-drilled holes on top of the machine. Slide a bolt into each hole until it stops. Hand tighten, and then use the Hex wrench to securely fasten the handlebars to the machine (see Photo 1).

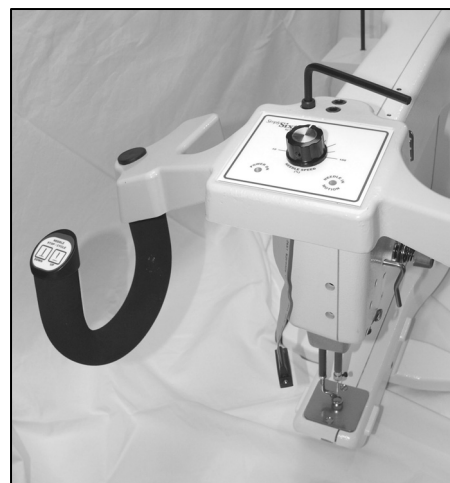

Photo 1

Once all three bolts are in place, plug the ribbon connector into the serial port on the back casing of the machine (see diagram B, #19). Make sure the pins are lined up so they are not damaged when the plug is pushed in. Push the plug securely in place.

Installing the Power Cord

Insert the cord into power connector on the rear of the machine (see Photo 2). Plug the three-prong end into power source.

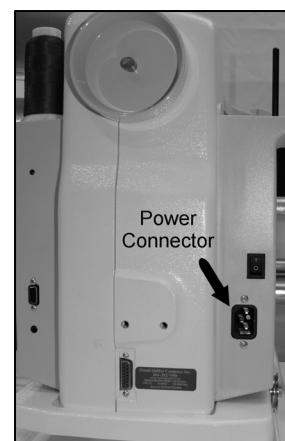

Photo 2

Note: After the power cord and front handlebar have been completely installed and plugged in, test the machine by turning the Simply Sixteen™ on/off switch to “on”. The green POWER ON LED should illuminate. If the light doesn’t illuminate, check that the handlebar cable on the side of the machine is plugged in securely, that your machine is turned on, and that the power cord is plugged into the machine as well as a power source.

Inserting (or changing) the Needle

Check that all power is turned off.

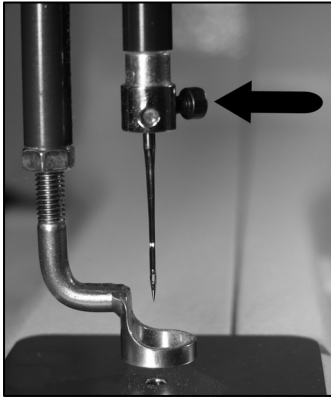
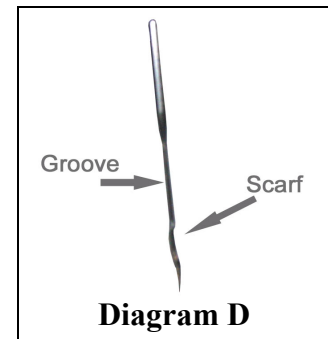

Photo 3

1. Move the needle bar to the highest position by turning the hand wheel or pressing the needle up/down control on the handles.
2. Loosen the needle bar clamp screw with the appropriate Hex wrench (see Photo 3).
3. With the scarf (small ground out section/dip on the back side of the needle just above the needle eye) facing toward the handwheel side of the machine, and the long groove down the front of the needle facing the bobbin case side (see diagram D), push the needle all the way up into the needle bar – until it can go no farther.

Important: Check the needle to confirm it is fully inserted. The needle bar has a stop/sight hole above the needle bar clamp screw – make sure the needle is touching the top of the stop/sight hole. If it is not, the machine timing will be off and it may be possible for the needle to collide with internal parts causing damage not covered by warranty.

4. *Carefully* tighten the needle bar clamp screw. Over tightening the needle clamp screw will result in damaged threads stripping the hole. Stripped holes are not covered under warranty. Another side effect of damaged threads from over tightening is the needle may be very tight when inserted up into the needle bar. To avoid over tightening the screw, put the long end of the Hex wrench into the screw and finger tighten only.



Note: Changing the needle is recommended for each new quilt loaded on the machine or any time the needle becomes bent, dull or burred.

Adjusting the Hopping Foot

The foot is adjusted at the factory and should not be moved without consulting the manufacturer.

Installing the Thread Mast



Photo 4

Locate the threaded hole on top of the machine near the rear by the hand wheel. The thread mast comes with the washer and nut on it. Remove the nut and washer, replace the nut onto the mast and then place the washer under the nut and onto the machine painted surface. The washer protects the painted surface when the nut is tightened. Tighten the mast clock wise until it is securely in place. Use the nut to secure the mast to the machine.

Note: The eyelets of the thread mast **MUST** be centered over the spool pins – so the cone will not pull, turn or tilt causing thread tension problems (see Photo 4).

Installing the Laser Stylus

Begin by locating the laser stylus guide post, the laser holder and the laser stylus.

To attach the laser stylus to the top of the machine:

1. Locate the threaded hole on top of the machine near the front (see diagram B, #20). The laser stylus guide post comes with the washer and nut on it. Remove the nut and washer, replace the nut onto the post and then place the washer under the nut and onto the machine painted surface. The washer protects the painted surface when the nut is tightened. Tighten the post clockwise until it is securely in place. Use the nut to secure the post to the machine.
2. Be sure the laser stylus is inserted into the laser clamp.
3. Slide the laser clamp over the post to the desired height.
4. Plug the laser into the top port on the side of the front electronic control pod (see diagram C, #29).

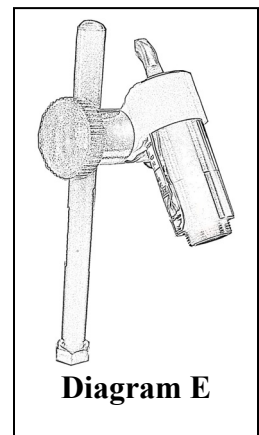

Diagram E

To attach the laser stylus to the side of the machine:

1. Place the nut on the laser stylus guide post with the washer under it and thread the laser guide post into the threaded hole at the front of the machine (see diagram A, #14), near the rear wheel base. Turn until securely in place. Lock in place with lock nut – the washer will be under the nut to protect the machine paint (see Photo 5). Note: An unused spool pin can also be used to mount the laser.

Follow steps 2-4 above



Photo 5

Laser Stylus Safety and Use Guidelines

Theory of Operation

The laser stylus projects a straight laser beam visible as a dot on surfaces it hits. The laser dot is used as a guide or stylus allowing you to stitch the same pattern onto a quilt that is being traced with the laser dot.

Laser Operation and Use

There is not a separate on/off switch for the laser. Power is supplied to the laser when it is plugged into the HQ Sixteen. Be sure the laser is attached to the HQ Sixteen and pointed downward toward the table before connecting it to the port. Never point it in a direction that would project the beam into someone's eyes. If the laser should cease to operate, check to ensure the plug is firmly seated into the Simply Sixteen™ laser port.

Caution: Use of controls or adjustments or performance of procedures other than those specified herein may result in hazardous radiation exposure.



Photo 6

Laser Focus/Laser Image Size

This high quality laser is focusable. The laser is focused by simply grasping the threaded housing surrounding the lens and turning clockwise or counter clockwise (see Photo 6). The laser image can be adjusted bigger or smaller. The direction of rotation needed is determined by the distance of the laser from the intended focal plane. Experiment by turning the threaded end to achieve your desired focal size.

Clamp Adjustment

The laser attaches to a mounting post. The post may be vertical or horizontal. The clamp is designed to articulate any direction by rotating the clamp on the post and pivoting the laser up or down. To make an adjustment, simply loosen the black thumbscrews, position, and retighten.

Location of Laser Labels

The label is attached to the case of the laser and contains an arrow which indicates the direction the laser light will shine when energized. The label must remain in place on the laser. Removal of the label will void the laser's warranty.

Threading the Machine

1. Pass the thread through **the thread mast** eyelet from back to front, continuing to thread guide **A**.
2. Continue to three-hole thread guide **B**. Wrap all three holes from back to front, handwheel side to needle side (see Detail 1 below).

Note: The purpose of this guide is to prevent loops of thread coming off the thread cone from going into the top tension as a knot causing thread breakage and bad tension. For most threads on a cone, it is important to thread all three holes for consistent results – should top thread tension need to be adjusted it should be done at the top tension assembly.

3. Thread continues through thread guide **C**, and then down to the **tension assembly** (see Detail 2 below).

NOTE: It is important that the thread is “flossed” up between the two tension discs. If the thread is not firmly in place between the two tension discs, the thread rests on top of the tension discs without tension and looping can occur.

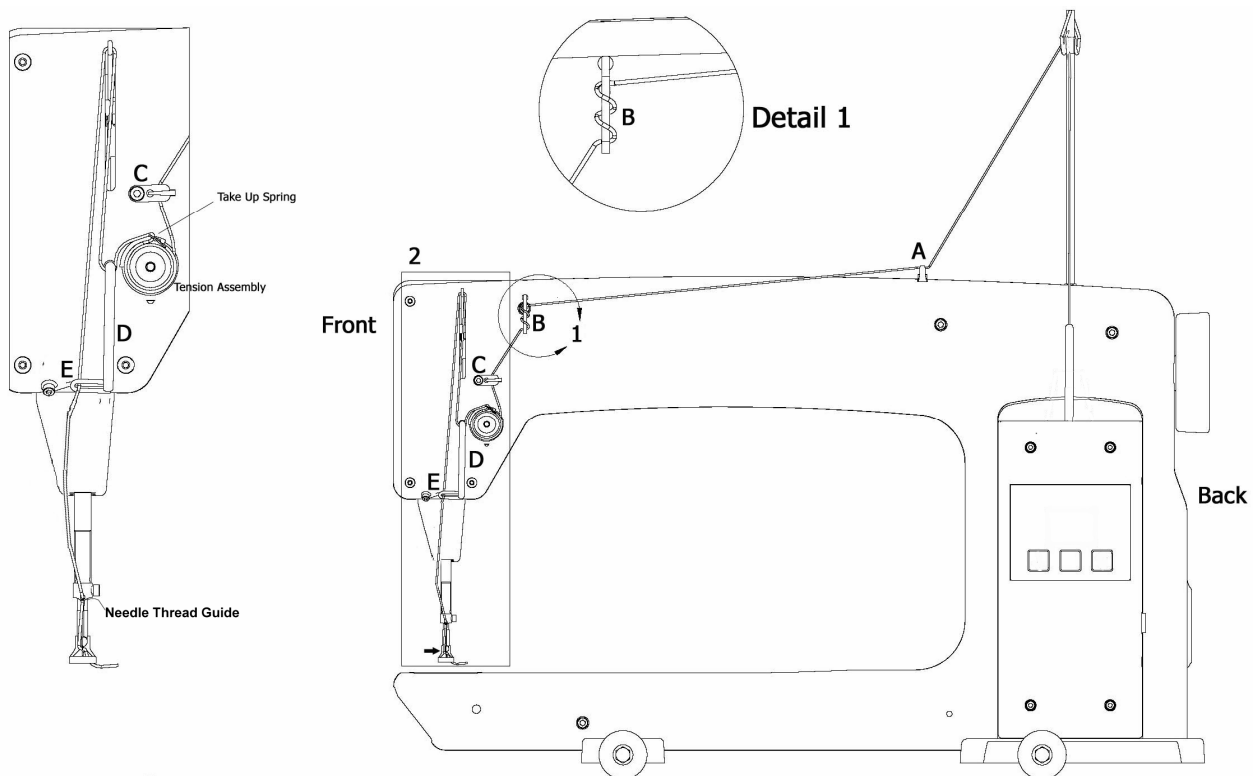

DETAIL 2
SCALE 1 : 1.5

Diagram F

4. Once the thread is in place, be sure that the thread catches on the **take up spring** and then pull it down under the stirrup (thread guide **D**).

5. Bring the thread back up through the **take up lever** from right to left, and then down through thread guide **E**.
 6. Pull the thread down to the **needle thread guide** and thread through the hole.
 7. Make sure the thread is following the groove down the front of the needle and **threads from front to back**. Note: Be careful that the thread does not twist around the needle.
- Note:** To test that the machine is threaded correctly and the tension is correct, carefully pull the needle thread - taking care to not bend the needle. It should pull smoothly with light to medium tension.

Important notes: The Simply Sixteen™ quilting machine does not have a presser foot lever or top tension release like a home sewing machine. On a home sewing machine the top tension is released when the presser foot is raised allowing the thread to come freely out of the machine. When a home machine is threaded the tension discs are released and open for the thread to easily fall between the tension discs. This is not the case with the Simply Sixteen™ quilting machine. Consequently the top tension is always tight and the tensions discs are never open. Therefore the thread must be pulled up between the tension discs or it will stay outside the discs and float without tension, causing serious tension problems and or thread nests. It is also possible to bend the needle while it is threaded if care is not taken while moving the machine around the quilt because the top tension is never released.

Optional Horizontal Spool Holder

1. An optional horizontal spool holder is available for metallic and specialty threads wound on a spool (not a cone).
2. The horizontal spool holder mounts on the laser stylus guide post on the top of the machine (see Photo 7).
3. When using threads on the Horizontal Spool Holder, skip thread guide A. Thread the top hole only of the three-hole thread guide B, back to front.



Photo 7

Bobbin and Thread Tension Adjustments

Inserting the Bobbin

1. Place the bobbin in the bobbin case so that the thread pulls off clockwise when viewing the open side.
2. Slide the thread through the slot and under the tension spring leaving 5-6 inches of thread hanging loose.
3. Do not lift the lever on bobbin case. Fit the bobbin case onto the hook spindle in the machine. Rotate the casing until the open throat keys into the middle notch in the hook. Push the casing in until it stops in place. Push inward until it clicks (see Photo 8).



Photo 8

Note: It is not suggested that the lever on the bobbin case be used for this installation. The latch lever should be used only for removal of the bobbin case.

4. Turn off the power switch while inserting the bobbin case or anytime the hands are near the needle area.

Drawing up the Bobbin Thread to the Top of the Quilt

1. After the machine is threaded, locate needle up button on the left handle.
2. With the needle in the up position, firmly hold the tail of the needle thread and press the needle up button with free hand. This will bring the needle back to the up position.
3. Pull the machine 2-3 inches away while holding the needle thread.
4. Bobbin thread will pull up through to the top allowing you to grasp the loop and pull it to the desired length.

Bobbin Tension

The bobbin tension is the foundation tension for the entire machine. To test that bobbin tension is correct, hold the bobbin case in the palm of your hand with the open end facing up - wrap the thread around your index finger and while pulling up on the thread and wiggling the finger front to back (not up and down which is not consistent), the bobbin case should lift up on its side, but NOT lift out of your hand. If it will not lift up onto its side, it is too loose and if it lifts out of you hand it is too tight. The small screw in the center of the tension spring is where the adjustment is made (see Photo 9) – Turn clockwise to tighten and counterclockwise to loosen the bobbin case tension.

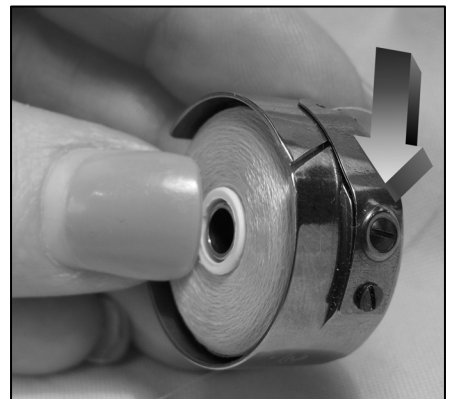

Photo 9

Top Tension

Puckering, gathers and thread breakage occur when the top tension is too tight. Loops and thread nests occur when the top thread tension is too loose. Tension may need to be adjusted depending on the fabric, thread or batting you are using on each project. The top thread tension is many times tighter than the bobbin case. If the bobbin case tension is too tight, a very tight top tension is required for tension balance.

Important: Top tension should be adjusted after the bobbin case foundation tension adjustment is made.

To adjust the top tension tighter, turn the tension knob clockwise. To loosen the tension, turn the tension knob counter-clockwise. If the bobbin case tension is adjusted a degree on the screw, the top tension may need to be adjusted a $\frac{1}{4}$ to $\frac{1}{2}$ turn to compensate or balance the tension.

Note: Before adjusting your top tension, remember to floss or pull the top thread up into the tension discs or it will float outside the discs providing little or no top tension. This could cause significant tension or nesting problems on the bottom side of the quilt.

Consistently using the same thread will reduce your tension issues. If you use multiple brands, weights, types, colors, qualities, and mixes of threads, many tension variables will be created and more tension adjustments will be required. Dark threads will be heavier (because of dye) than light threads of the same weight, type and brand, also affecting tension settings. The more consistent one is, the fewer variables will be involved.

Maintenance

Cleaning and Lubricating the Machine

Only use light sewing machine oil in the Simply Sixteen™. Internal oiling is not necessary on the Simply Sixteen™ except when the machine is taken to a service technician for routine maintenance and cleaning. **The bobbin basket assembly, however, needs regular lubricating.** Failure to keep the bobbin assembly lubricated can cause severe damage to the machine. To lubricate, turn off the machine. Clean around the bobbin assembly with a soft brush to remove lint.

Put 1/2 drop (very small drop) of oil on the hook in the bobbin assembly (see Photo 10). (Remove bobbin and case before oiling). The frequency depends upon the usage of the machine. Lubricating is recommended before running the machine if it has not been used regularly, or every other bobbin change if used frequently. Always sew a scrap piece as oil may cling to thread. Over oiling can cause excess dripping from the bobbin assembly. Lack of lubricant may be noticed by a change in the sound of the machine and will affect stitch quality.

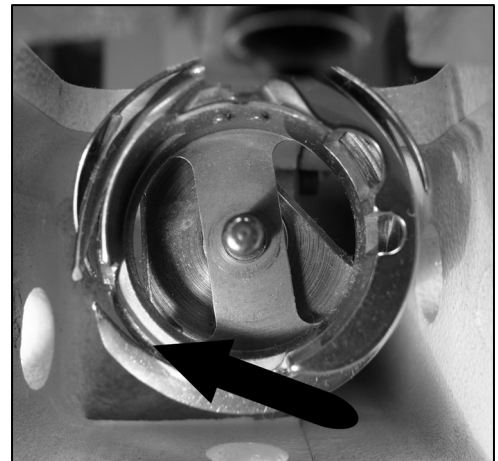

Photo 10

Front Handlebar Controls



The following functions take effect by pressing and then quickly releasing the button.

Note: When the machine is stopped, pay attention to the position of the needle when pushing Needle Up or Needle Down. Where the needle begins when the button is pushed will determine the effect of the Needle Up and Needle Down controls.

	Function
INDICATOR LIGHTS Power On Light Needle in Motion Light	<p>Located on the left side of the speed dial, the GREEN LED light is illuminated to indicate that the machine is plugged in and power is on.</p> <p>Located on the right side of the speed dial, the RED LED light is illuminated when the needle should be moving.</p> <p>Note: Caution should be taken when the needle is in motion. If the RED light is on and the needle is NOT in motion, this indicates a MOTOR STALL condition has occurred. Turn off the power to the machine and clear the cause of the stall (thread lock, tight hand wheel, material too thick, etc). NEVER WORK AROUND THE NEEDLE WHILE THE RED LIGHT IS ON. TURN THE POWER OFF FIRST.</p>
Needle Speed Dial	<p>Turn the dial to set the speed of the machine. The needle speed is a percentage of the top speed of the machine (1,500 stitches per minute).</p> <p>At 10%, the machine is stitching at approximately 150 stitches per minute.</p> <p>At 50%, the machine is stitching at approximately 750 stitches per minute.</p> <p>At 100%, the machine is stitching at approximately 1,500 stitches per minute.</p>

POD Controls

(for controlling the machine from the rear)

The front handlebar **MUST BE INSTALLED** for the Simply Sixteen™ to function correctly.

Note: When the machine is stopped, pay attention to the position of the needle when pushing Needle Up or Needle Down. Where the needle begins will determine the effect of the Needle Up and Needle Down controls.

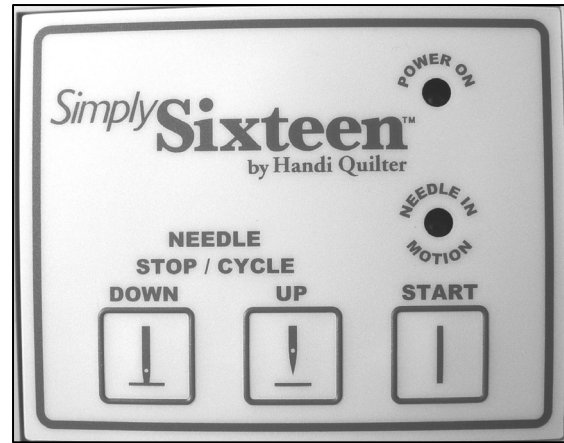

	Function
INDICATOR LIGHTS Power On Light Needle in Motion Light	<p>This GREEN LED light is illuminated to indicate that the machine is plugged in and power is on.</p> <p>This RED LED light is illuminated when the needle should be moving.</p> <p>Note: Caution should be taken when the needle is in motion. If the RED light is on and the needle is NOT in motion, this indicates a MOTOR STALL condition has occurred. Turn off the power to the machine and clear the cause of the stall (thread lock, tight hand wheel, material too thick, etc). NEVER WORK AROUND THE NEEDLE WHILE THE RED LIGHT IS ON. TURN THE POWER OFF FIRST.</p>
NEEDLE STOP CYCLE Needle Up Needle Down	<p>If the needle is in motion (the red LED light is on), push to stop the machine in the needle up position.</p> <p>Half Stitch: <i>If the machine is stopped in the needle down position, push the needle up button to produce a half stitch (the machine will make a half stitch and stop with the needle up).</i></p> <p>Whole Stitch: <i>If the machine is stopped in the needle up position, push the needle up button to produce a full stitch (the machine will make a full stitch and stop with the needle up).</i></p> <p>If the needle is in motion (the red LED light is on), push to stop the machine in the needle down position.</p> <p>Half Stitch: <i>If the machine is stopped in the needle up position, push the needle down button to produce a half stitch (the machine will make a half stitch and stop with the needle down).</i></p> <p>Whole Stitch: <i>If the machine is stopped in the needle down position, push the needle down button to produce a full stitch (the machine will make a full stitch and stop in needle down).</i></p>
Start	Starts the machine.

To Begin Quilting

Thread Requirements

Threads have a tendency to dry or wet rot over a period of time. Be sure to choose high quality threads for your valuable heirloom quilts. Most machine quilting threads on the market today are acceptable.

Needle Requirements

For general quilting, a size 16/100 needle will accommodate most threads and fabrics.

Heavier threads, such as top stitch and some decorative threads, require a larger needle such as 18/110. Lofty bats and heavier fabrics such as denim, canvas or densely woven fabric may also require a larger needle.

To Prepare for Quilting

With any quilting machine, it is important to understand the basics of free motion quilting. The Simply Sixteen™ Quilting Machine does not have feed dogs like domestic machines; therefore, the fabric does not automatically feed under the hopping foot. The operator should synchronize the speed as well as the movement of the machine to get an even, consistent stitch.

In order to become comfortable with the free motion of the Simply Sixteen™, users can begin with a few “beginner” techniques.

Set the machine at a medium speed (about 50%) and begin moving it until you become accustomed to the resistance. By moving the machine faster, the stitches begin to elongate. The stitch speed can either be increased or the machine can be moved slower to get the stitches back to the desired length. By moving the machine slower, the stitches get shorter and can build up on top of each other, breaking the thread or making it extremely difficult to unpick. The stitch speed can be decreased, while maintaining a constant motion with the machine to bring the stitches back to the desired length.

When pressing START on the front handlebar or on the rear pod, make certain to begin moving the machine immediately. If the needle stitches in one place too long, the stitches build up on top of each other causing the thread to break. When bringing the machine to a complete stop press the STOP button at the same moment the machine stops moving. If the machine is still moving when the STOP button is pressed, it can cause deflection in the needle, causing it to break.

When quilting, relax your hands and maintain a light touch on the handles bars. Gripping the handlebar too tightly can cause uneven patterns and irregular circles and loops. The Simply Sixteen™, combined with any one of its home machine quilting frames will give you a smooth even glide.

Troubleshooting

Stitches are Skipping	Corrective Measure
<ul style="list-style-type: none"> ▶ The needle is damaged, dull, bent, or installed improperly ▶ Incorrect needle size ▶ The needle has not been positioned properly ▶ Fabric is too tight on the frame ▶ Upper tension too tight ▶ Improper threading 	<ul style="list-style-type: none"> ▶ Replace the needle often, normally once or twice per day for continuous quilting or at least once per quilt. Use proper needles. ▶ Always change the needle if the needle has struck any hard object such as a straight pin, etc. The tip of the needle can become damaged or burred, resulting in fabric damaged as well as skipped stitches and thread breakage. ▶ Always change the needle if it has been hit, bumped or pulled off center while maneuvering the machine about the quilt. A slightly bent needle can be a major cause of skipped stitches. ▶ Check for the proper size of needle for the work and thread being applied to the quilting operation. Some battings and fabrics used in quilting may constrict or impede the thread passing through the front groove of the needle. This diminishes the loop lift required for stitch formation. Typically, a larger needle will solve the problem; however, it has been found that certain smaller sizes of needles as well as the use of ball pointed needles solve some specific problems. ▶ Position the needle properly to the needle bar. Inspect the position of the needle to make sure that the needle is at the 6 o'clock position (see Photo 11)—If you stand directly in front of the needle (facing the bobbin case side of the machine), you will see the entire needle eye directly facing you. This is 6 o'clock position. The needle must not be allowed to rotate in the needle clamp negative to 6 o'clock. (Example: 5 o'clock is rotating the needle slightly right. This will skip stitches). The needle can sometimes be rotated to 7 o'clock (slightly left) in order to adjust for a more positive thread loop pickup by the hook point. (7 o'clock is the maximum tolerance for rotation). Make sure the needle is installed all the way into the needle bar to the needle stop hole in the needle bar and the long groove is toward the front (bobbin case side) and the scarf/scooped out part is toward the handwheel. ▶ Loosen fabric on the frame. Fabric that is rolled too tight causes the fibers to separate. This reduces the needle friction on the thread resulting in a smaller thread loop. ▶ Loosen upper tension. ▶ Inspect that the thread take-up lever, thread stirrup or tension spring are all threaded correctly.
The Needle Breaks	Corrective Measure
<ul style="list-style-type: none"> ▶ The needle is bent or not installed properly ▶ The needle hits the throat plate 	<ul style="list-style-type: none"> ▶ Replace or correctly change the needle. Make sure that the needle is pushed up into the needle bar clamp until it can go no farther (visually check that it is up to the top of the stop/sight hole above the needle bar clamp screw). Failure to do so can cause damage in the bobbin area and throat plate. ▶ Correctly position the needle, throat plate or presser foot.
Stitches are Puckered	Corrective Measure
<ul style="list-style-type: none"> ▶ The hopping foot applies too much pressure to the material ▶ The tension is not balanced ▶ Needle too thick for material 	<ul style="list-style-type: none"> ▶ Decrease the pressure on the presser foot by loosening the nut at the base of the hopping foot shaft. Adjust to the proper height. Note: When tightening the nut on the hopping foot shaft be careful not to tighten so tight that it rotates the bar. ▶ Balance the tension of the needle thread with the bobbin thread. ▶ Replace the needle for one better suited for the fabric.
Stitch Quality is Poor	Corrective Measure
<ul style="list-style-type: none"> ▶ The tension is not balanced ▶ Bobbin case is damaged, corroded, dirty, etc 	<ul style="list-style-type: none"> ▶ Adjust the tension of the needle thread if it is not balanced with that of the bobbin thread. ▶ Since thread slides over the surface of the bobbin case at a high speed, make sure the case is free of any material that could impede thread passage through the machine.
Tension is Poor	Corrective Measure
<ul style="list-style-type: none"> ▶ "Fuzz" caught under the tension spring in the bobbin 	<ul style="list-style-type: none"> ▶ If using short staple threads, inexpensive or industrial threads or coated threads, lint and other material will build up under the tension leaf spring and begin to lift the spring, reducing the spring's ability to compress against the thread. By inserting a needle under the spring and clearing out the lint, the bobbin tension will return fairly close to its preset tension.

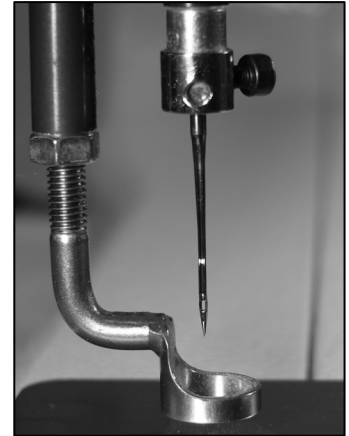

Photo 11

Hand Wheel Won't Rotate	Corrective Measure
<ul style="list-style-type: none"> ▶ Thread is entangled and caught in the hook 	<ul style="list-style-type: none"> ▶ Turn off the machine and unplug the machine from the electrical outlet. Lubricate the hook, strongly turn the hand wheel clockwise and if necessary counterclockwise several times, and then remove the thread caught in the hook.
Thread Nests Under Quilt	Corrective Measure
<ul style="list-style-type: none"> ▶ Not enough tension on top thread ▶ Moving the machine too fast for needle speed selected. ▶ Improper threading 	<ul style="list-style-type: none"> ▶ Check that the machine is threaded correctly. Make certain that thread is snugly in place between the two tension discs. If machine is threaded correctly, tighten top tension by rotating the tension knob clockwise. ▶ Synchronize machine movement and needle speed to get roughly 6-8 stitches per inch. Elongated stitches are an indication of moving the machine too fast for the current speed. ▶ Refer to threading diagram and threading instructions (page 7).
Hard to Guide Machine	Corrective Measure
<ul style="list-style-type: none"> ▶ Carriage wheels not centered on track ▶ Thread caught in wheels 	<ul style="list-style-type: none"> ▶ Center the carriage wheels on top of the continuous track. Check that the machine carriage has not "jumped" track. Slightly loosen wheel on one side to allow machine to more easily follow track alignment. ▶ Remove all thread or debris in wheels. Check that the tracks are free of lint and threads.
Motor Fails to Run	Corrective Measure
<ul style="list-style-type: none"> ▶ On/Off switch turned off ▶ Machine not receiving power 	<ul style="list-style-type: none"> ▶ Turn the machine on by using the switch on the back electrical control pod. ▶ Check that the power connector is plugged into the back of the machine and the three-prong end is plugged into power source
Uneven Quilt Design	Corrective Measure
<ul style="list-style-type: none"> ▶ Take-up rollers may be bowed or bent ▶ Leaders are stretched/worn 	<ul style="list-style-type: none"> ▶ Make certain that the fabric is not rolled too tight, causing the fabric to stretch. Check that poles overlap and snap together with the push pin so bowing won't occur. ▶ If fabric is beginning to stretch or fray, contact Handi Quilter Company for replacement leaders.
Needle Thread Breaks	Corrective Measure
<ul style="list-style-type: none"> ▶ Thread cones/spools may have abraded thread casing, severe twisting or thread rot ▶ Top and bobbin tensions not balanced ▶ The machine head has been threaded incorrectly or thread spools are not positioned correctly ▶ Particles in tension discs ▶ Bobbin rotation is not smooth ▶ Needle is burred, bent or dull, or installed incorrectly ▶ Needle not suited for thread ▶ Hesitating too long at one point in pattern ▶ Improper needle/hook relationship ▶ Damage or "Burr" at needle hole of throat plate or other thread handling part ▶ Wrong type of needle 	<ul style="list-style-type: none"> ▶ Look for severe twisting of threads when approximately 12 to 15 inches has been pulled off, with the ends pinched together. Cotton threads are particularly susceptible to dry rot or wet rot which makes thread brittle. ▶ The top thread tension is many times tighter than the bobbin case. If the bobbin case tension is too tight, a very tight top tension is required for tension balance. See Page 8-9 for proper adjustment. ▶ Check that the machine is threaded correctly. ▶ Inspect for accidental double wrapping of thread on thread guides. ▶ Inspect the thread mast, making sure that the eyelets of the mast are directly over the spools. ▶ Inspect the vertical positioning of the thread cones. Tipped cones can dramatically affect thread tension and can cause breakage. ▶ Inspect for particles and remove any fuzz or debris. ▶ Change the bobbin. The slightest hesitation of the bobbin rotation can be the cause of dramatic tension change and thread breakage. ▶ Change the needle at least once per quilt. Make sure the needle is installed to the top of the stop hole in the needle bar ▶ Replace the needle to one better suited for the thread. Use the proper size needle. ▶ Move more quickly so stitches don't overlap or build up. When starting the machine, begin moving immediately. Sewing in one place too long will cause the thread to break. ▶ Timing-consult a repair technician. ▶ If thread is shredding at the throat plate, check for burrs or jagged edges. Gently rub with metal cloth to remove the sharp edge. Consult a repair technician to polish any hard to reach or delicate areas, or if the burr is inside the throat. ▶ Use needles recommended by Handi Quilter Company. Using the wrong needle with a smaller shank diameter causes many problems. For example, a system 1738 or 287WH needle with a shank diameter of 1.64mm will fit loosely into the needle bar clamp. This condition allows the

<p>▶ Other possible problems:</p>	<p>needles to fit into the clamp at an angle causing the following problems: Needle too far away from the hook point, (skipped stitches).</p> <ul style="list-style-type: none"> • Needle too close to hook, causing friction and possible collision of hook point and needle, (broken thread). • Needle plate damage • Hook damage • Broken needles or damaged needle bar clamp
<p>Motor Stall</p>	<p>Corrective Measure</p>
<p>▶ Motor Stall—RED LED (needle in motion light) is on but needle is not moving</p>	<ul style="list-style-type: none"> ▶ TURN POWER OFF. MOTOR STALL indicates that the motor is not responding properly to the speed controls. This may be caused by a thread lock, mechanical obstruction or an electrical problem. ▶ Clear any thread from the bobbin area ONLY after turning off the power to the machine. ▶ Turn the handwheel and check for tightness. ▶ The motor stall may re-occur if it is caused by an electrical problem. Turn the machine off and then back on again to reset.

* If the troubleshooting above does not eliminate the problem, please consult the representative where you purchased the Simply Sixteen™.



***The Undisputed Leader
in Home Machine Quilting Systems***

www.HandiQuilter.com